

TYPICAL WIRING DIAGRAM

NOTE: A larger version of the Typical Wiring Diagram is available in the product's operator manual, refer to DSE Publication: 057-259 DSE8660 MKII Operator Manual available from www.deepseaelectronics.com for more information.

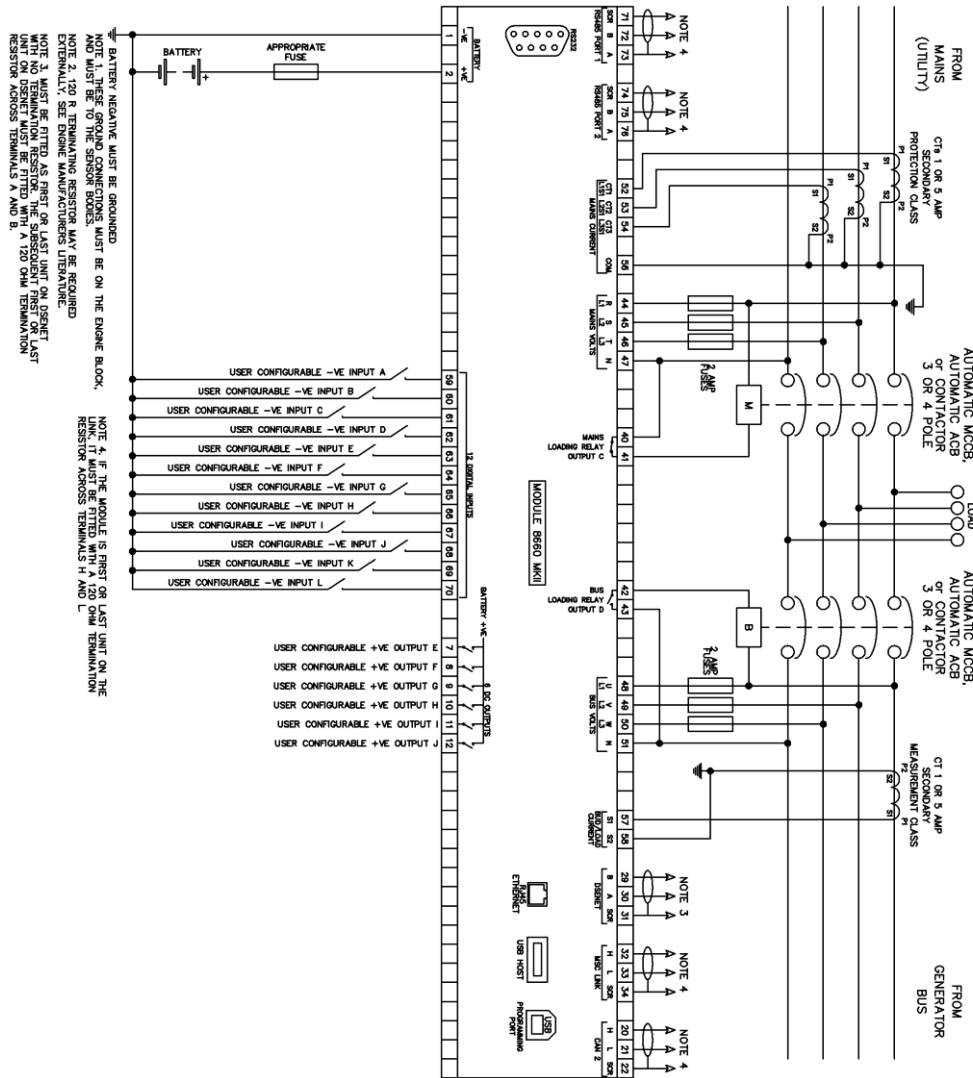

<p>Deep Sea Electronics Ltd. Tel: +44 (0)1723 890099 Email: support@deepseaelectronics.com Web: www.deepseaelectronics.com</p>	<p>Deep Sea Electronics Inc. Tel: +1 (815) 316 8706 Email: usasupport@deepseaelectronics.com Web: www.deepseaelectronics.com</p>
---	--



ACCESSING THE MAIN CONFIGURATION EDITOR

- Ensure the generator bus is dead and the module is in STOP mode by pressing the (Stop/Reset) button.
 - Press the (Stop/Reset) and (Tick) buttons simultaneously.
 - If a module security PIN has been set, the PIN number request is then shown:
-
- The first '#' changes to '0'. Press the (Up) or (Down) button to adjust it to the correct value.
 - Press the (Right) button when the first digit is correctly entered. The digit previously entered now shows '#' for security.
 - Repeat this process for the other digits of the PIN number. Press the (Left) button to move back to adjust one of the previous digits.
 - When the (Tick) button is pressed after editing the final PIN digit, the PIN is checked for validity. If the number is not correct, the PIN must be re-entered.
 - If the PIN has been successfully entered (or the module PIN has not been enabled), the editor is displayed:
-

EDITING A PARAMETER

- Enter the editor as described above.
- Press the (Right) or (Left) buttons to cycle to the section to view/change.
- Press the (Up) or (Down) buttons to select the parameter to view/change within the currently selected section.
- To edit the parameter, press the (Tick) button to enter edit mode. The parameter begins to flash to indicate editing.
- Press the (Up) or (Down) buttons to change the parameter to the required value.
- Press the (Tick) button to save the value. The parameter ceases flashing to indicate that it has been saved.
- To exit the editor and save the changes, press and hold the (Tick) button.
- To exit the editor and not save the changes, press and hold the (Stop/Reset) button.

NOTE: If the editor is left inactive for the duration of the LCD Page Timer, it is automatically exited to ensure security.

NOTE: The PIN number is automatically reset when the editor is exited (manually or automatically) to ensure security.

NOTE: Comprehensive module configuration is possible using the DSE Configuration Suite PC Software, refer to DSE publication 057-257 DSE8660 MKII Configuration Suite PC Software Manual available from www.deepseaelectronics.com.

NOTE: Depending upon module configuration, some parameters in the Main and Running Editors may not be available. For more information refer to DSE publication 057-257 *DSE8660 MKII Configuration Suite PC Software Manual* available from www.deepseaelectronics.com

MAIN CONFIGURATION EDITOR PARAMETERS

Section	Parameter As Shown On Display	Values
Display	Contrast	0%
	Language	English, Other.
	Current Date and Time	DD:MM:YY, hh:mm:ss
Timers	LCD Page Timer	0 h 0 m 0 s
	Scroll Delay	0 h 0 m 0 s
	Battery Under Voltage Warning Delay	0 h 0 m 0 s
	Battery Over Voltage Warning Delay	0 h 0 m 0 s
	Start Delay Off Load	0 h 0 m 0 s
	Start Delay On Load	0 h 0 m 0 s
	Start Delay Telemetry	0 h 0 m 0 s
	Start Delay Mains Fail	0 h 0 m 0 s
	Mains Transient Delay	0.0 s
	Return Delay	0 h 0 m 0 s
	Mains Transfer Time	0 m 0.0 s
	Mains Over Zero Seq Volt Delay	0.0 s
	Mains Under Pos Seq Volt Delay	0.0 s
	Mains Over Neg Seq Volts Delay	0.0 s
	Mains Asymmetry High Delay	0.0 s
	Bus Over Zero Seq Volts Delay	0.0 s
	Bus Under Pos Seq Volts Delay	0.0 s
	Bus Over Neg Seq Volts Delay	0.0 s
	Bus Asymmetry High Delay	0.0 s
	Mains	Under Voltage Trip
Over Voltage Trip		0 V
Under Frequency Trip		0.0 Hz
Over Frequency Trip		0.0 Hz
CT Primary		0 A Power Cycle After Exit
CT Secondary		0 A Power Cycle After Exit
Mains Rating		0 kW
Mains Rating		0 kvar
Mains Over Zero Seq Volt		Active / Inactive
Mains Over Zero Seq Volt		0.0 V
Mains Under Pos Seq Volt		Active / Inactive
Mains Under Pos Seq Volt		0.0 V
Mains Over Neg Seq Volts		Active / Inactive
Mains Over Neg Seq Volts		0.0 V
Mains Asymmetry High		Active / Inactive
Mains Asymmetry High		0.0 V
AC System		3 Phase, 4 Wire
Bus	Start Delay On Load	0 h 0 m 0 s
	Battery Under Voltage Warning	Active / Inactive
	Battery Under Voltage Warning Delay	0 h 0 m 0 s
	Battery Under Voltage Warning	0.0 V
	Battery Over Voltage Warning	Active / Inactive
	Battery Over Voltage Warning Delay	0 h 0 m 0 s
	Battery Over Voltage Warning	0.0 V
	Load Level For More Sets	0 %
	Load Level For Less Sets	0 %
	Ramp Up Rate	0.0 %
	Ramp Down Rate	0.0 %
	Bus Over Zero Seq Volts	Active / Inactive
	Bus Over Zero Seq Volts	0.0 V
	Bus Under Pos Seq Volts	Active / Inactive
	Bus Under Pos Seq Volts	0.0 V
	Bus Over Neg Seq Volts	Active / Inactive
	Bus Over Neg Seq Volts	0.0 V
	Bus Asymmetry High	Active / Inactive
	Bus Asymmetry High	0.0 V
	Enable MSC Compatibility	Active / Inactive

MAIN CONFIGURATION EDITOR PARAMETERS (CONTINUED)

Section	Parameter As Shown On Display	Values
Comms	RS232 Port	Baud Rate
	RS232 Port	Slave ID
	RS485 Port	Baud Rate
	RS485 Port	Slave ID
Schedule	Schedule	Active / Inactive
	Schedule Bank 1 Period	Weekly / Monthly,
	Island / Parallel / Off Load / Auto Start Inhibit, Week, Start Time, Run Time and Day. Selection (1 to 8)	Press to begin editing then up or down when selecting the different parameters.
	Schedule Bank 2 Period	Weekly / Monthly,
	Island / Parallel / Off Load / Auto Start Inhibit, Week, Start Time, Run Time and Day. Selection (1 to 8)	Press to begin editing then up or down when selecting the different parameters.

DIMENSIONS AND MOUNTING

Parameter	Specification
Dimensions	245 mm X 184 mm X 51 mm (9.6" X 7.2" X 2.0")
Panel Cutout	220 mm X 160 mm (8.7" X 6.3")
Weight	0.98 kg (2.16 lb)
Operating Temperature with Standard Display	-30 °C to +70 °C (-22 °F to +158 °F)
Operating Temperature with Heated Display	-40 °C to +70 °C (-40 °F to +158 °F)
Storage Temperature	-40 °C to +80 °C (-40 °F to +176 °F)

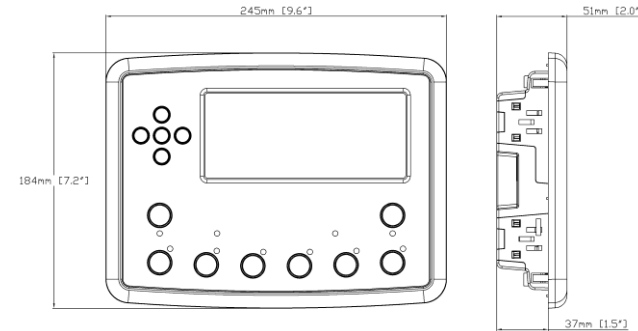

FIXING CLIPS

NOTE: In conditions of excessive vibration, mount the control panel on suitable anti-vibration mountings

- The module is held into the control panel fascia using the supplied fixing clips.
- Withdraw the fixing clip screw (turn anticlockwise) until only the pointed end is protruding from the clip.
 - Insert the three 'prongs' of the fixing clip into the slots in the side of the DSE module's case.
 - Pull the fixing clip backwards (towards the back of the module) ensuring all three prongs of the clip are inside their allotted slots.
 - Turn the fixing clip screws clockwise until they make contact with the panel fascia.
 - Turn the screws a quarter of a turn to secure the module into the control panel's fascia. Care must be taken not to over tighten the fixing clip screws.

ACCESSING THE 'RUNNING' CONFIGURATION EDITOR

- The 'Running' Configuration Editor is enterable without making the generator bus dead. All protections remain active whilst using the 'Running' Configuration Editor.



- Press and hold the (Tick) button to enter and exit the Running Editor.

RUNNING CONFIGURATION EDITOR PARAMETERS

Section	Parameter As Shown On Display	Values
Display	Contrast	0 %
	Language	English, Other
	Commissioning Screens	Active / Inactive
	Mains Decoupling Test Mode	Active / Inactive
	Voltage Adjust (manual mode only, bus breaker open)	0 V
	Frequency Adjust (manual mode only, bus breaker open)	0 Hz
	Auxiliary Mains Fail Out of Sync Reset	Active / Inactive
Power Levels	Power Control Mode	Constant Power / Frequency-Power / Voltage-Power
	kvar Control Mode	Constant Power Factor / Voltage-Reactive Power / Power-Power Factor / Constant Reactive Power
	Load Parallel Power	0 %
	Load Parallel kvar	0 %
	Load Parallel PF	0.00 pf

REQUIREMENTS FOR UL CERTIFICATION

WARNING! More than one live circuit exists, see diagram overleaf for further information.

Specification	Description
Screw Terminal Tightening Torque	• 4.5 lb-in (0.5 Nm)
Conductors	<ul style="list-style-type: none"> Terminals suitable for connection of conductor size 13 AWG to 20 AWG (0.5 mm² to 2.5 mm²). Conductor protection must be provided in accordance with NFPA 70, Article 240 Low voltage circuits (35 V or less) must be supplied from the engine starting battery or an isolated secondary circuit. The communication, sensor, and/or battery derived circuit conductors shall be separated and secured to maintain at least ¼" (6 mm) separation from the generator and mains connected circuit conductors unless all conductors are rated 600 V or greater.
Current Inputs	• Must be connected through UL Listed or recognized isolating current transformers with the secondary rating of 5 A max.
Communication Circuits	• Must be connected to communication circuits of UL Listed equipment
DC Output Pilot Duty	• 0.5 A
Mounting	<ul style="list-style-type: none"> Suitable for flat surface mounting in Type 1 Enclosure Type rating with surrounding air temperature -22 °F to +122 °F (-30 °C to +50 °C) Suitable for pollution degree 3 environments when voltage sensing inputs do not exceed 300 V. When used to monitor voltages over 300 V device to be installed in an unventilated or filtered ventilation enclosure to maintain a pollution degree 2 environment.
Maximum Operating Temperature	• 122 °F (50 °C)